

PCD Tip Front Corner

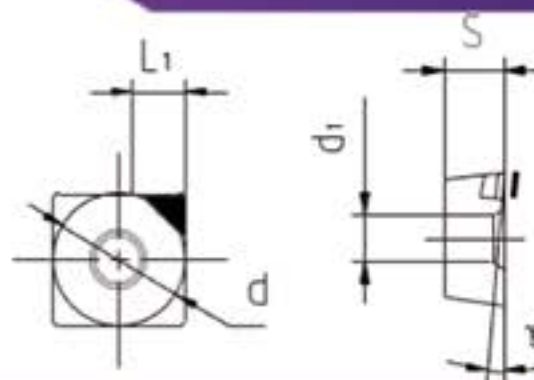

Model	Size				Material		
	d	S	d ₁	L ₁	GT25	GT10	GT302
SCGW060204SF03-X1	6.35	2.38	2.8	2.8	●	●	●
SCGW060204SF05-X1					●	●	●
SCGW060204SF07-X1					●	●	●
SCGW060208SF03-X1	6.35	2.38	2.8	2.8	●	●	●
SCGW060208SF05-X1					●	●	●
SCGW060208SF07-X1					●	●	●
SCGW09T304SF03-X1	9.525	3.97	2.8	3.1	●	●	●
SCGW09T304SF05-X1					●	●	●
SCGW09T304SF07-X1					●	●	●
SCGW09T308SF03-X1	9.525	3.97	4.4	3.1	●	●	●
SCGW09T308SF05-X1					●	●	●
SCGW09T308SF07-X1					●	●	●
SCGW120404SF03-X1	12.7	4.76	5.5	4.5	●	●	●
SCGW120404SF05-X1					●	●	●
SCGW120404SF07-X1					●	●	●
SCGW120408SF03-X1	12.7	4.76	5.5	4.5	●	●	●
SCGW120408SF05-X1					●	●	●
SCGW120408SF07-X1					●	●	●

PCD Tip with a Front Angle of 0 Degrees

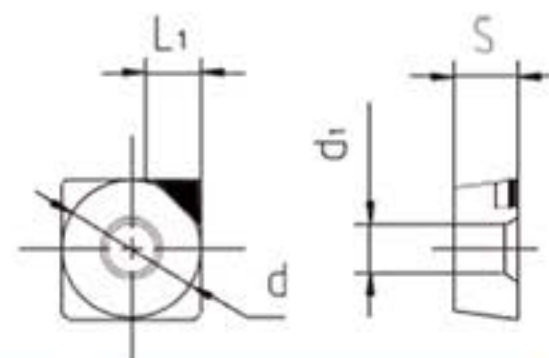

Model	Size				Material		
	d	S	d ₁	L ₁	GT25	GT10	GT302
SCGW060204SF00-X1	6.35	2.38	2.8	2.8	●	●	●
SCGW060208SF00-X1	6.35	2.38	2.8	2.8	●	●	●
SCGW09T304SF00-X1	9.525	3.97	2.8	3.1	●	●	●
SCGW09T308SF00-X1	9.525	3.97	4.4	3.1	●	●	●
SCGW120404SF00-X1	12.7	4.76	5.5	4.5	●	●	●
SCGW120408SF00-X1	12.7	4.76	5.5	4.5	●	●	●

PCD Tip Front Corner

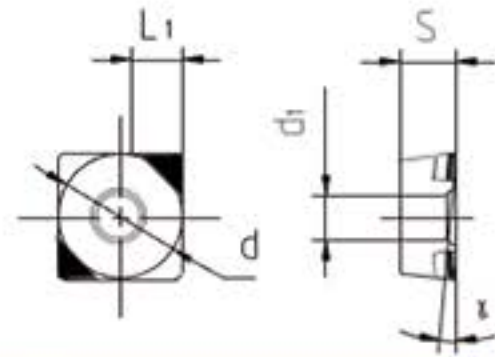

Model	Size				Material		
	d	S	d ₁	L ₁	GT25	GT10	GT302
SCGW060204SF03-X2	6.35	2.38	2.8	2.8	●	●	●
SCGW060204SF05-X2					●	●	●
SCGW060204SF07-X2					●	●	●
SCGW060208SF03-X2	6.35	2.38	2.8	2.8	●	●	●
SCGW060208SF05-X2					●	●	●
SCGW060208SF07-X2					●	●	●
SCGW09T304SF03-X2	9.525	3.97	2.8	3.1	●	●	●
SCGW09T304SF05-X2					●	●	●
SCGW09T304SF07-X2					●	●	●
SCGW09T308SF03-X2	9.525	3.97	4.4	3.1	●	●	●
SCGW09T308SF05-X2					●	●	●
SCGW09T308SF07-X2					●	●	●
SCGW120404SF03-X2	12.7	4.76	5.5	4.5	●	●	●
SCGW120404SF05-X2					●	●	●
SCGW120404SF07-X2					●	●	●
SCGW120408SF03-X2	12.7	4.76	5.5	4.5	●	●	●
SCGW120408SF05-X2					●	●	●
SCGW120408SF07-X2					●	●	●

PCD Tip with a Front Angle of 0 Degrees

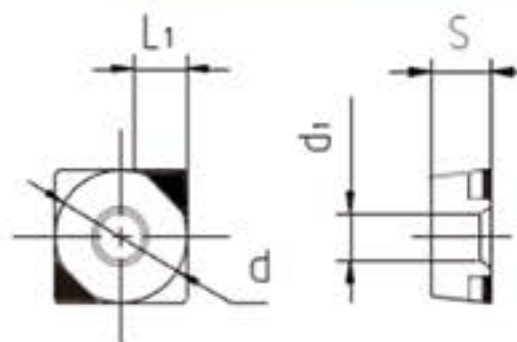

Model	Size				Material		
	d	S	di	L1	GT25	GT10	GT302
SCGW060204SF00-X2	6.35	2.38	2.8	2.8	●	●	●
SCGW060208SF00-X2	6.35	2.38	2.8	2.8	●	●	●
SCGW09T304SF00-X2	9.525	3.97	2.8	3.1	●	●	●
SCGW09T308SF00-X2	9.525	3.97	4.4	3.1	●	●	●
SCGW120404SF00-X2	12.7	4.76	5.5	4.5	●	●	●
SCGW120408SF00-X2	12.7	4.76	5.5	4.5	●	●	●

PCD Tip with a Front Angle of 0 Degrees

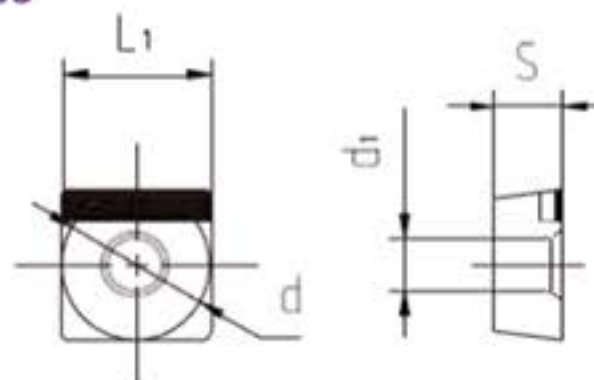
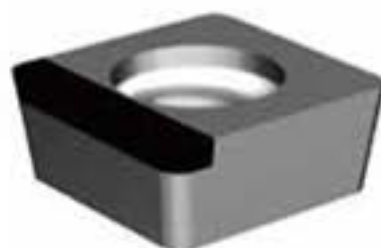

Model	Size				Material		
	d	S	di	L1	GT25	GT10	GT302
SCGW060204LF00-R1	6.35	2.38	2.8	6.2	●	●	●
SCGW060208LF00-R1	6.35	2.38	2.8	6.2	●	●	●
SCGW09T304LF00-R1	9.525	3.97	4.4	9.3	●	●	●
SCGW09T308LF00-R1	9.525	3.97	4.4	9.3	●	●	●
SCGW120404LF00-R1	12.7	4.76	5.5	12.4	●	●	●
SCGW120408LF00-R1	12.7	4.76	5.5	12.4	●	●	●
SCGW060204LF00-L1	6.35	2.38	2.8	6.2	●	●	●
SCGW060208LF00-L1	6.35	2.38	2.8	6.2	●	●	●
SCGW09T304LF00-L1	9.525	3.97	4.4	9.3	●	●	●
SCGW09T308LF00-L1	9.525	3.97	4.4	9.3	●	●	●
SCGW120404LF00-L1	12.7	4.76	5.5	12.4	●	●	●
SCGW120408LF00-L1	12.7	4.76	5.5	12.4	●	●	●

PCD Tip Front Corner

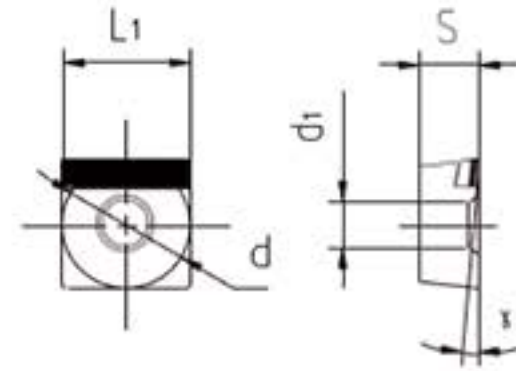

Model	Size				Material		
	d	S	d ₁	L ₁	GT25	GT10	GT302
SCGW060204LF03-R1	6.35	2.38	2.8	6.2	●	●	●
SCGW060204LF04-R1					●	●	●
SCGW060204LF05-R1					●	●	●
SCGW060204LF07-R1					●	●	●
SCGW060208LF03-R1	6.35	2.38	2.8	6.2	●	●	●
SCGW060208LF04-R1					●	●	●
SCGW060208LF05-R1					●	●	●
SCGW060208LF07-R1					●	●	●
SCGW09T304LF03-R1	9.525	3.97	4.4	9.3	●	●	●
SCGW09T304LF04-R1					●	●	●
SCGW09T304LF05-R1					●	●	●
SCGW09T304LF07-R1					●	●	●
SCGW09T308LF03-R1	9.525	3.97	4.4	9.3	●	●	●
SCGW09T308LF04-R1					●	●	●
SCGW09T308LF05-R1					●	●	●
SCGW09T308LF07-R1					●	●	●
SCGW120404LF03-R1	12.7	4.76	5.5	12.4	●	●	●
SCGW120404LF04-R1					●	●	●
SCGW120404LF05-R1					●	●	●
SCGW120404LF07-R1					●	●	●
SCGW120408LF03-R1	12.7	4.76	5.5	12.4	●	●	●
SCGW120408LF04-R1					●	●	●
SCGW120408LF05-R1					●	●	●
SCGW120408LF07-R1					●	●	●
SCGW060204LF03-L1	6.35	2.38	2.8	6.2	●	●	●
SCGW060204LF04-L1					●	●	●
SCGW060204LF05-L1					●	●	●
SCGW060204LF07-L1					●	●	●
SCGW060208LF03-L1	6.35	2.38	2.8	6.2	●	●	●
SCGW060208LF04-L1					●	●	●
SCGW060208LF05-L1					●	●	●
SCGW060208LF07-L1					●	●	●
SCGW09T304LF03-L1	9.525	3.97	4.4	9.3	●	●	●
SCGW09T304LF04-L1					●	●	●
SCGW09T304LF05-L1					●	●	●
SCGW09T304LF07-L1					●	●	●

SCGW09T308LF03-L1	9.525	3.97	4.4	9.3	●	●	●
SCGW09T308LF04-L1					●	●	●
SCGW09T308LF05-L1					●	●	●
SCGW09T308LF07-L1					●	●	●
SCGW120404LF03-L1	12.7	4.76	5.5	12.4	●	●	●
SCGW120404LF04-L1					●	●	●
SCGW120404LF05-L1					●	●	●
SCGW120404LF07-L1					●	●	●
SCGW120408LF03-L1	12.7	4.76	5.5	12.4	●	●	●
SCGW120408LF04-L1					●	●	●
SCGW120408LF05-L1					●	●	●
SCGW120408LF07-L1					●	●	●

PCD Tip and Chip-Breaking Grooves

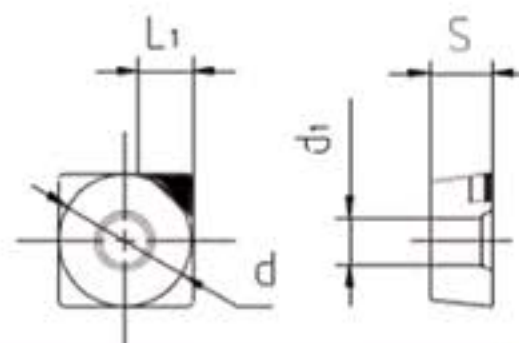

Model	Size				Material		
	d	S	d ₁	L ₁	GT25	GT10	GT302
SCGT09T304SF00-X1	9.525	3.97	4.4	4.4	●	●	●
SCGT09T308SF00-X1	9.525	3.97	4.4	4.3	●	●	●
SCGT120404SF00-X1	12.7	4.76	5.5	4.4	●	●	●
SCGT120408SF00-X1	12.7	4.76	5.5	4.3	●	●	●

PCD Tip and Chip-Breaking Grooves

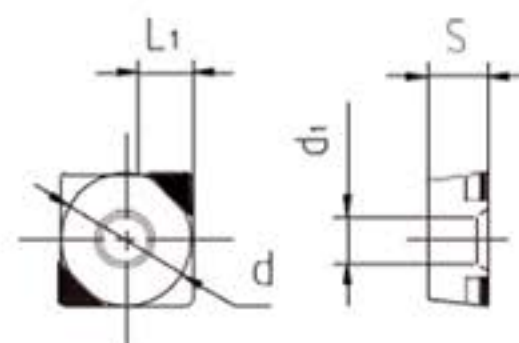

Model	Size				Material		
	d	S	d ₁	L ₁	GT25	GT10	GT302
SCGT09T304SF00-X2	9.525	3.97	4.4	4.4	●	●	●
SCGT09T308SF00-X2	9.525	3.97	4.4	4.3	●	●	●
SCGT120404SF00-X2	12.7	4.76	5.5	4.4	●	●	●
SCGT120408SF00-X2	12.7	4.76	5.5	4.3	●	●	●

PCD Tip Front Corner

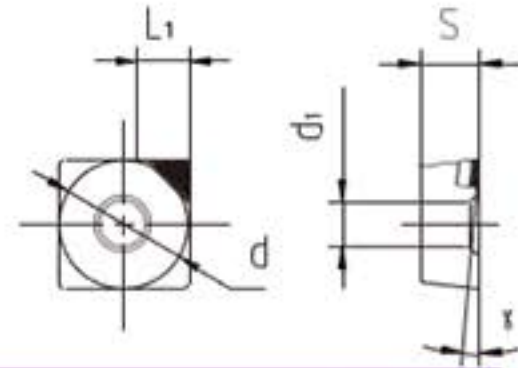

Model	Size				Material		
	d	S	d ₁	L ₁	GT25	GT10	GT302
SPGW 060304 SF03-X1	6.35	3.18	2.8	2.8	●	●	●
SPGW 060304 SF05-X1					●	●	●
SPGW 060304 SF07-X1					●	●	●
SPGW 060308 SF03-X1	6.35	3.18	2.8	2.8	●	●	●
SPGW 060308 SF05-X1					●	●	●
SPGW 060308 SF07-X1					●	●	●
SPGW 09T304 SF03-X1	9.525	3.97	4.4	3.1	●	●	●
SPGW 09T304 SF05-X1					●	●	●
SPGW 09T304 SF07-X1					●	●	●
SPGW 09T308 SF03-X1	9.525	3.97	4.4	3.1	●	●	●
SPGW 09T308 SF05-X1					●	●	●
SPGW 09T308 SF07-X1					●	●	●

PCD Tip with a Front Angle of 0 Degrees

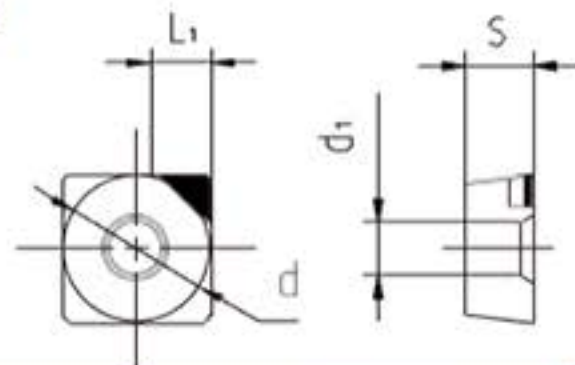

Model	Size				Material		
	d	S	d ₁	L ₁	GT25	GT10	GT302
SPGW060304SF00-X1	6.35	3.18	2.8	2.8	●	●	●
SPGW060308SF00-X1	6.35	3.18	2.8	2.8	●	●	●
SPGW09T304SF00-X1	9.525	3.97	4.4	3.1	●	●	●
SPGW09T308SF00-X1	9.525	3.97	4.4	3.1	●	●	●

PCD Tip Front Corner

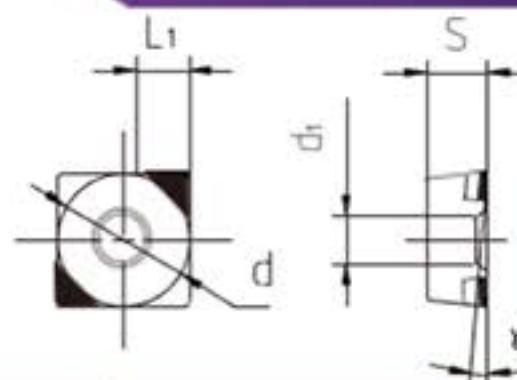

Model	Size				Material		
	d	S	d ₁	L ₁	GT25	GT10	GT302
SPGW 060304 SF03-X2	6.35	3.18	2.8	2.8	●	●	●
SPGW 060304 SF05-X2					●	●	●
SPGW 060304 SF07-X2					●	●	●
SPGW 060308 SF03-X2	6.35	3.18	2.8	2.8	●	●	●
SPGW 060308 SF05-X2					●	●	●
SPGW 060308 SF07-X2					●	●	●
SPGW 09T304 SF03-X2	9.525	3.97	4.4	3.1	●	●	●
SPGW 09T304 SF05-X2					●	●	●
SPGW 09T304 SF07-X2					●	●	●
SPGW 09T308 SF03-X2	9.525	3.97	4.4	3.1	●	●	●
SPGW 09T308 SF05-X2					●	●	●
SPGW 09T308 SF07-X2					●	●	●

PCD Tip with a Front Angle of 0 Degrees

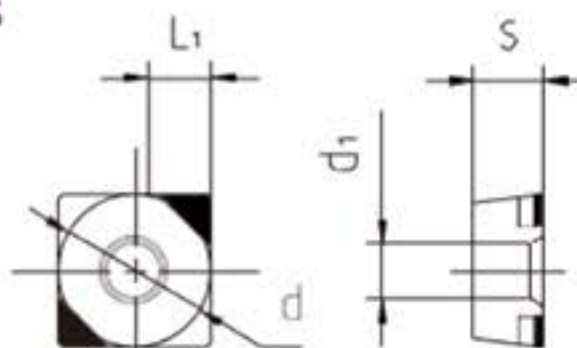

Model	Size				Material		
	d	S	d ₁	L ₁	GT25	GT10	GT302
SPGW060304SF00-X2	6.35	3.18	2.8	2.8	●	●	●
SPGW060308SF00-X2	6.35	3.18	2.8	2.8	●	●	●
SPGW09T304SF00-X2	9.525	3.97	4.4	3.1	●	●	●
SPGW09T308SF00-X2	9.525	3.97	4.4	3.1	●	●	●

PCD Tip Front Corner

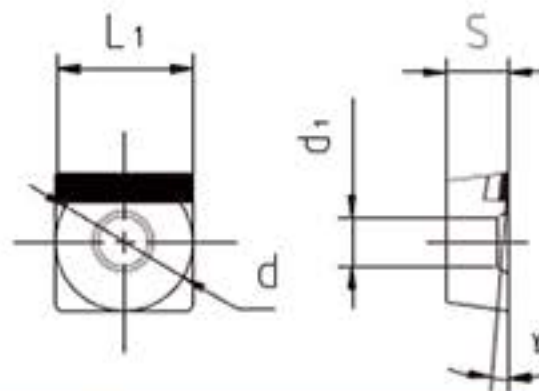
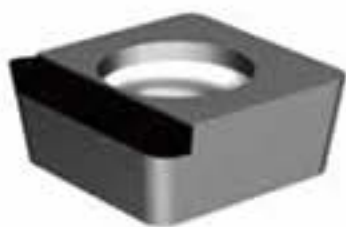

Model	Size				Material		
	d	S	d ₁	L ₁	GT25	GT10	GT302
SPGW060304LF03-R1	6.35	3.18	2.8	6.2	●	●	●
SPGW060304LF04-R1					●	●	●
SPGW060304LF05-R1					●	●	●
SPGW060304LF07-R1					●	●	●
SPGW060308LF03-R1	6.35	3.18	2.8	6.2	●	●	●
SPGW060308LF04-R1					●	●	●
SPGW060308LF05-R1					●	●	●
SPGW060308LF07-R1					●	●	●
SPGW09T304LF03-R1	9.525	3.97	4.4	9.3	●	●	●
SPGW09T304LF04-R1					●	●	●
SPGW09T304LF05-R1					●	●	●
SPGW09T304LF05-R1					●	●	●
SPGW09T308LF03-R1	9.525	3.97	4.4	9.3	●	●	●
SPGW09T308LF04-R1					●	●	●
SPGW09T308LF05-R1					●	●	●
SPGW09T308LF07-R1					●	●	●
SPGW060304LF03-L1	6.35	3.18	2.8	6.2	●	●	●
SPGW060304LF04-L1					●	●	●
SPGW060304LF05-L1					●	●	●
SPGW060304LF07-L1					●	●	●
SPGW060308LF03-L1	6.35	3.18	2.8	6.2	●	●	●
SPGW060308LF04-L1					●	●	●
SPGW060308LF05-L1					●	●	●
SPGW060308LF07-L1					●	●	●
SPGW09T304LF03-L1	9.525	3.97	4.4	9.3	●	●	●
SPGW09T304LF04-L1					●	●	●
SPGW09T304LF05-L1					●	●	●
SPGW09T304LF07-L1					●	●	●
SPGW09T308LF03-L1	9.525	3.97	4.4	9.3	●	●	●
SPGW09T308LF04-L1					●	●	●
SPGW09T308LF05-L1					●	●	●
SPGW09T308LF07-L1					●	●	●

PCD Tip with a Front Angle of 0 Degrees

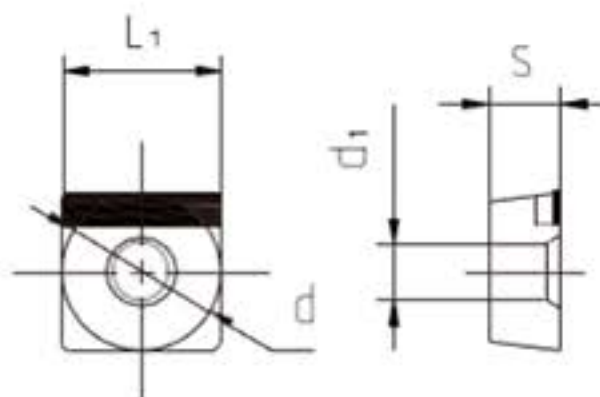

Model	Size				Material		
	d	S	d ₁	L ₁	GT25	GT10	GT302
SPGW060304LF00-R1	6.35	3.18	2.8	6.2	●	●	●
SPGW060308LF00-R1	6.35	3.18	2.8	6.2	●	●	●
SPGW09T304LF00-R1	9.525	3.97	4.4	9.3	●	●	●
SPGW09T308LF00-R1	9.525	3.97	4.4	9.3	●	●	●
SPGW060304LF00-L1	6.35	3.18	2.8	6.2	●	●	●
SPGW060308LF00-L1	6.35	3.18	2.8	6.2	●	●	●
SPGW09T304LF00-L1	9.525	3.97	4.4	9.3	●	●	●
SPGW09T308LF00-L1	9.525	3.97	4.4	9.3	●	●	●

PCD Tip and Chip-Breaking Grooves

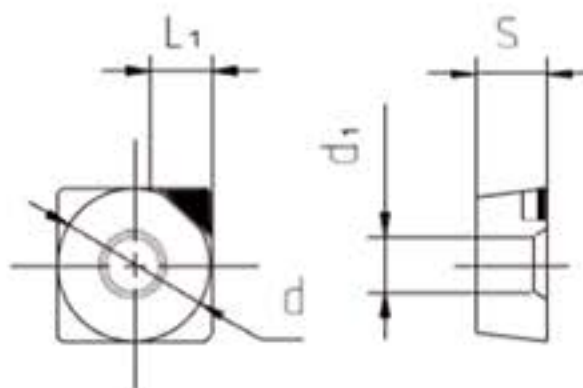

Model	Size				Material		
	d	S	d ₁	L ₁	GT25	GT10	GT302
SPGT060304SF00-X1	6.35	3.18	2.8	2.8	●	●	●
SPGT060308SF00-X1	6.35	3.18	2.8	2.8	●	●	●
SPGT09T304SF00-X1	9.525	3.97	4.4	3.1	●	●	●
SPGT09T308SF00-X1	9.525	3.97	4.4	3.1	●	●	●

PCD Tip and Chip-Breaking Grooves

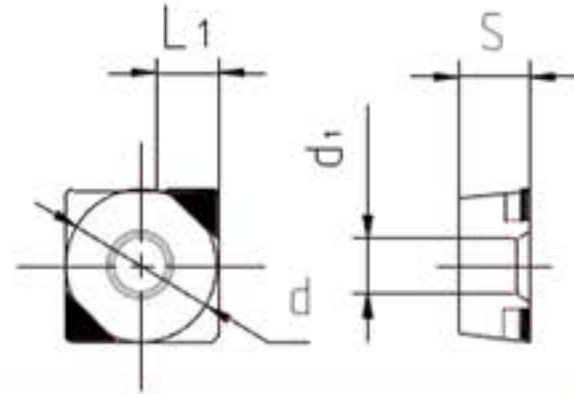

Model	Size				Material		
	d	S	d _i	L _i	GT25	GT10	GT302
SPGT060304SF00-X2	6.35	3.18	2.8	2.8	●	●	●
SPGT060308SF00-X2	6.35	3.18	2.8	2.8	●	●	●
SPGT09T304SF00-X2	9.525	3.97	4.4	3.1	●	●	●
SPGT09T308SF00-X2	9.525	3.97	4.4	3.1	●	●	●

PCD Tip with a Front Angle of 0 Degrees

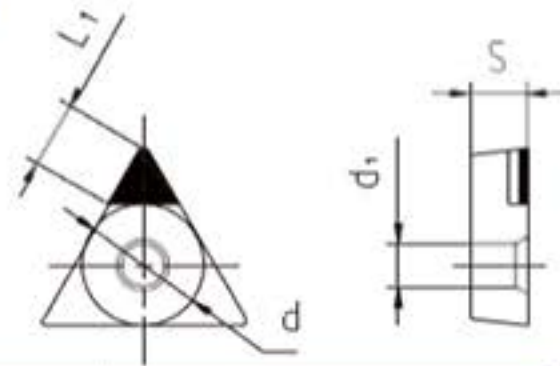

Model	Size				Material		
	d	S	d _i	L _i	GT25	GT10	GT302
TCGW090204SF00-X1	5.56	2.38	2.5	3.4	●	●	●
TCGW090208SF00-X1	5.56	2.38	2.5	3.1	●	●	●
TCGW110204SF00-X1	6.35	2.38	2.8	3.8	●	●	●
TCGW110208SF00-X1	6.35	2.38	2.8	3.5	●	●	●
TCGW16T304SF00-X1	9.525	3.97	4.4	5.4	●	●	●
TCGW16T308SF00-X1	9.525	3.97	4.4	5.1	●	●	●