

PCD Tip Chip-Breaking Grooves

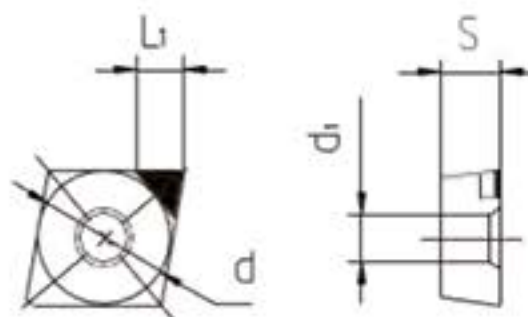

Model	Size				Material		
	d	S	d ₁	L ₁	GT25	GT10	GT302
CPGT060204SF00-X1	6.35	2.38	2.8	3.1	●	●	●
CPGT060208SF00-X1	6.35	2.38	2.8	3	●	●	●
CPGT09T304SF00-X1	9.525	3.97	4.4	3.5	●	●	●
CPGT09T308SF00-X1	9.525	3.97	4.4	3.4	●	●	●

PCD Tip with a Front Angle of 0 Degrees

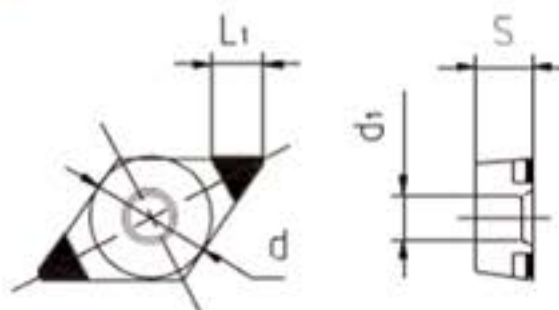
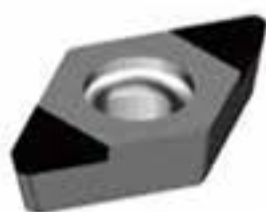

Model	Size				Material		
	d	S	d ₁	L ₁	GT25	GT10	GT302
DCGW070202SF00-X2	6.35	2.38	2.8	3.7	●	●	●
DCGW070204SF00-X2	6.35	2.38	2.8	3.4	●	●	●
DCGW070208SF00-X2	6.35	2.38	2.8	3	●	●	●
DCGW11T304SF00-X2	9.525	3.97	4.4	3.9	●	●	●
DCGW11T308SF00-X2	9.525	3.97	4.4	3.5	●	●	●

PCD Tip Front Corner

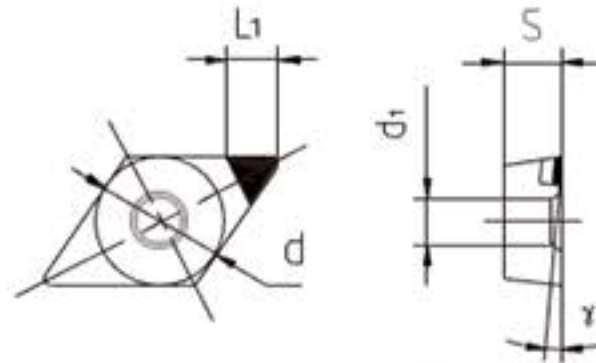

Model	Size				Material		
	d	S	d ₁	L ₁	GT25	GT10	GT302
DCGW 070202 SF03-X1	6.35	2.38	2.8	3.7	●	●	●
DCGW 070202 SF04-X1					●	●	●
DCGW 070202 SF05-X1					●	●	●
DCGW 070202 SF07-X1					●	●	●
DCGW 070202 SF10-X1					●	●	●
DCGW 070204 SF03-X1	6.35	2.38	2.8	3.4	●	●	●
DCGW 070204 SF04-X1					●	●	●
DCGW 070204 SF05-X1					●	●	●
DCGW 070204 SF07-X1					●	●	●
DCGW070204SF10-X1					●	●	●
DCGW070208SF03-X1	6.35	2.38	2.8	3	●	●	●
DCGW070208SF04-X1					●	●	●
DCGW 070208 SF05-X1					●	●	●
DCGW070208SF07-X1					●	●	●
DCGW070208SF10-X1					●	●	●
DCGW11T304SF03-X1	9.525	3.97	4.4	3.9	●	●	●
DCGW11T304SF04-X1					●	●	●
DCGW 11T304 SF05-X1					●	●	●
DCGW11T304SF07-X1					●	●	●
DCGW11T304SF10-X1					●	●	●
DCGW11T308SF03-X1	9.525	3.97	4.4	3.5	●	●	●
DCGW11T308SF04-X1					●	●	●
DCGW 11T308 SF05-X1					●	●	●
DCGW 11T308 SF07-X1					●	●	●
DCGW11T308SF10-X1					●	●	●

PCD Tip Front Corner

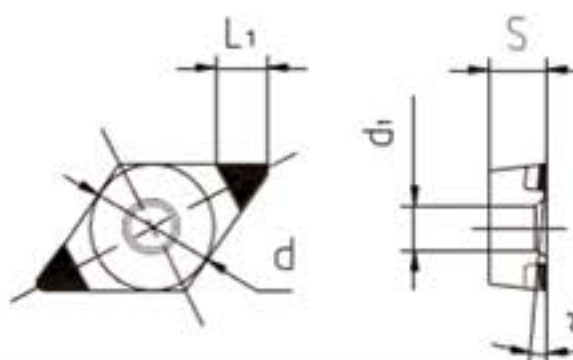

Model	Size				Material		
	d	S	d ₁	L ₁	GT25	GT10	GT302
DCGW0702025F03-X2	6.35	2.38	2.8	3.7	●	●	●
DCGW0702025F04-X2					●	●	●
DCGW0702025F05-X2					●	●	●
DCGW0702025F07-X2					●	●	●
DCGW0702025F010-X2					●	●	●
DCGW0702025F015-X2					●	●	●
DCGW0702045F03-X2	6.35	2.38	2.8	3.4	●	●	●
DCGW0702045F04-X2					●	●	●
DCGW0702045F05-X2					●	●	●
DCGW0702045F07-X2					●	●	●
DCGW0702045F010-X2					●	●	●
DCGW0702045F015-X2					●	●	●
DCGW0702085F03-X2	6.35	2.38	2.8	3	●	●	●
DCGW0702085F04-X2					●	●	●
DCGW0702085F05-X2					●	●	●
DCGW0702085F07-X2					●	●	●
DCGW0702085F010-X2					●	●	●
DCGW0702085F015-X2					●	●	●
DCGW11T3045F03-X2	9.525	3.97	4.4	3.9	●	●	●
DCGW11T3045F04-X2					●	●	●
DCGW11T3045F05-X2					●	●	●
DCGW11T3045F07-X2					●	●	●
DCGW11T3045F010-X2					●	●	●
DCGW11T3045F015-X2					●	●	●
DCGW11T3085F03-X2	9.525	3.97	4.4	3.5	●	●	●
DCGW11T3085F04-X2					●	●	●
DCGW11T3085F05-X2					●	●	●
DCGW11T3085F07-X2					●	●	●
DCGW11T3085F010-X2					●	●	●
DCGW11T3085F015-X2					●	●	●

PCD Tip and Chip-Breaking Grooves

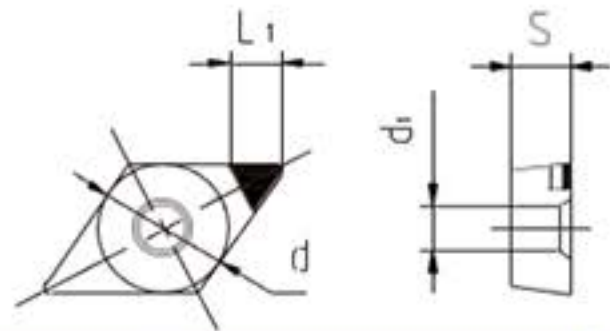
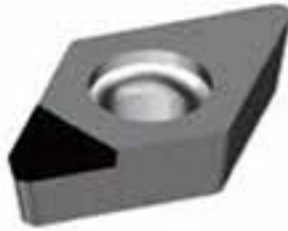

Model	Size				Material		
	d	S	d _i	L ₁	GT25	GT10	GT302
DCGT070202SF00-X1	6.35	2.38	2.8	3.7	●	●	●
DCGT070204SF00-X1	6.35	2.38	2.8	3.4	●	●	●
DCGT11T302SF00-X1	9.525	3.97	4.4	3.9	●	●	●
DCGT11T304SF00-X1	9.525	3.97	4.4	3.9	●	●	●
DCGT11T308SF00-X1	9.525	3.97	4.4	3.5			

PCD Tip with a Front Angle of 0 Degrees

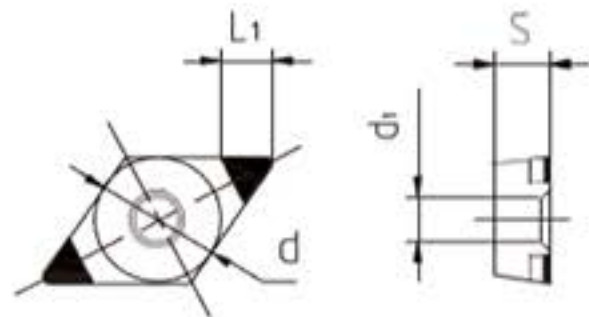
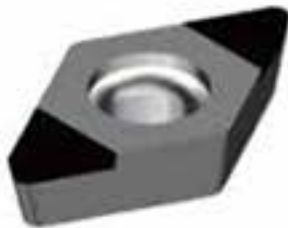

Model	Size				Material		
	d	S	d _i	L ₁	GT25	GT10	GT302
DPGW070202SF00-X2	6.35	2.38	2.8	3.7	●	●	●
DPGW070204SF00-X2	6.35	2.38	2.8	3.4	●	●	●
DPGW070208SF00-X2	6.35	2.38	2.8	3	●	●	●
DPGW11T304SF00-X2	9.525	3.97	4.4	3.9	●	●	●
DPGW11T308SF00-X2	9.525	3.97	4.4	3.5	●	●	●

PCD Tip Front Corner

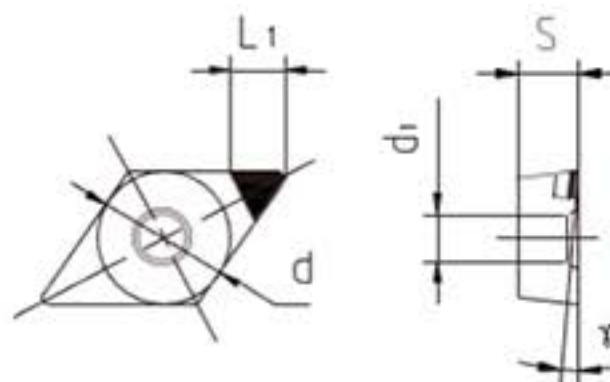
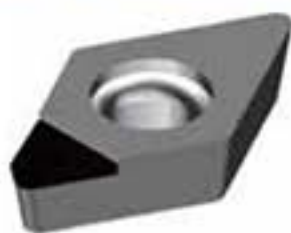

Model	Size				Material		
	d	S	d ₁	L ₁	GT25	GT10	GT302
DPGW070202SF03-X1	6.35	2.38	2.8	3.7	●	●	●
DPGW070202SF05-X1					●	●	●
DPGW070202SF07-X1					●	●	●
DPGW070202SF10-X1					●	●	●
DPGW070204SF03-X1	6.35	2.38	2.8	3.4	●	●	●
DPGW070204SF05-X1					●	●	●
DPGW070204SF07-X1					●	●	●
DPGW070204SF10-X1					●	●	●
DPGW070208SF03-X1	6.35	2.38	2.8	3	●	●	●
DPGW070208SF05-X1					●	●	●
DPGW070208SF07-X1					●	●	●
DPGW070208SF10-X1					●	●	●
DPGW11T304SF03-X1	9.525	3.97	4.4	3.9	●	●	●
DPGW11T304SF05-X1					●	●	●
DPGW11T304SF07-X1					●	●	●
DPGW11T304SF10-X1					●	●	●
DPGW11T308SF03-X1	9.525	3.97	4.4	3.5	●	●	●
DPGW11T308SF05-X1					●	●	●
DPGW11T308SF07-X1					●	●	●
DPGW11T308SF10-X1							

PCD Tip Front Corner

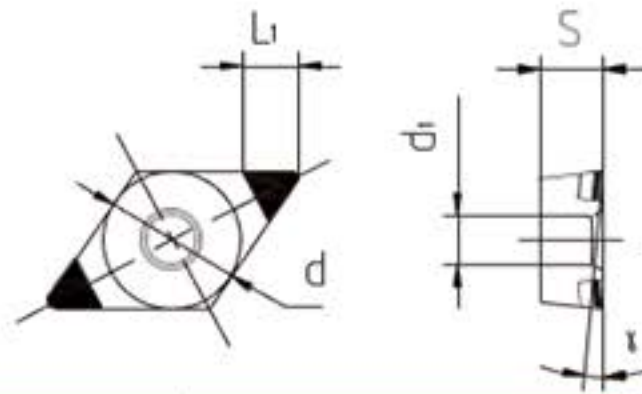
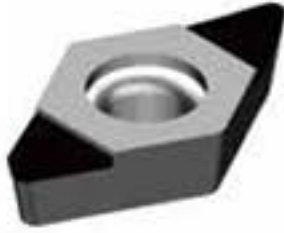

Model	Size				Material		
	d	S	d _i	L ₁	GT25	GT10	GT302
DPGW070202SF03-X2	6.35	2.38	2.8	3.7	●	●	●
DPGW070202SF05-X2					●	●	●
DPGW070204SF03-X2	6.35	2.38	2.8	3.7	●	●	●
DPGW070204SF05-X2					●	●	●
DPGW070208SF03-X2	6.35	2.38	2.8	3.4	●	●	●
DPGW070208SF05-X2					●	●	●
DPGW11T304SF03-X2	9.525	3.97	4.4	3.9	●	●	●
DPGW11T304SF05-X2					●	●	●
DPGW11T308SF03-X2	9.525	3.97	4.4	3.5	●	●	●
DPGW11T308SF05-X2					●	●	●

PCD Tip and Chip-Breaking Grooves

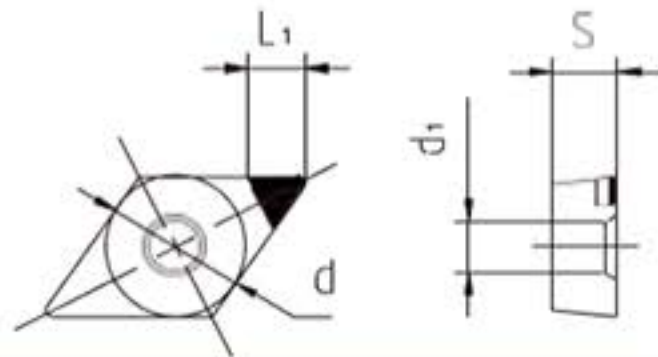
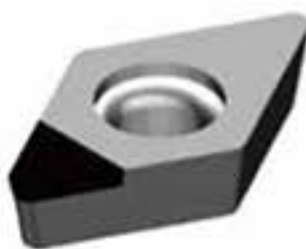

Model	Size				Material		
	d	S	d _i	L ₁	GT25	GT10	GT302
DPGT070202SF00-X1	6.35	2.38	2.8	3.7	●	●	●
DPGT070204SF00-X1	6.35	2.38	2.8	3.4	●	●	●
DPGT11T302SF00-X1	9.525	3.97	4.4	3.9	●	●	●
DPGT11T304SF00-X1	9.525	3.97	4.4	3.9	●	●	●
DPGT11T308SF00-X1	9.525	3.97	4.4	3.5	●	●	●